

J&S Electronics

13925 Parkway Dr. Garden Grove, CA 92843
 (714) 534-6975 www.jandssafeguard.com

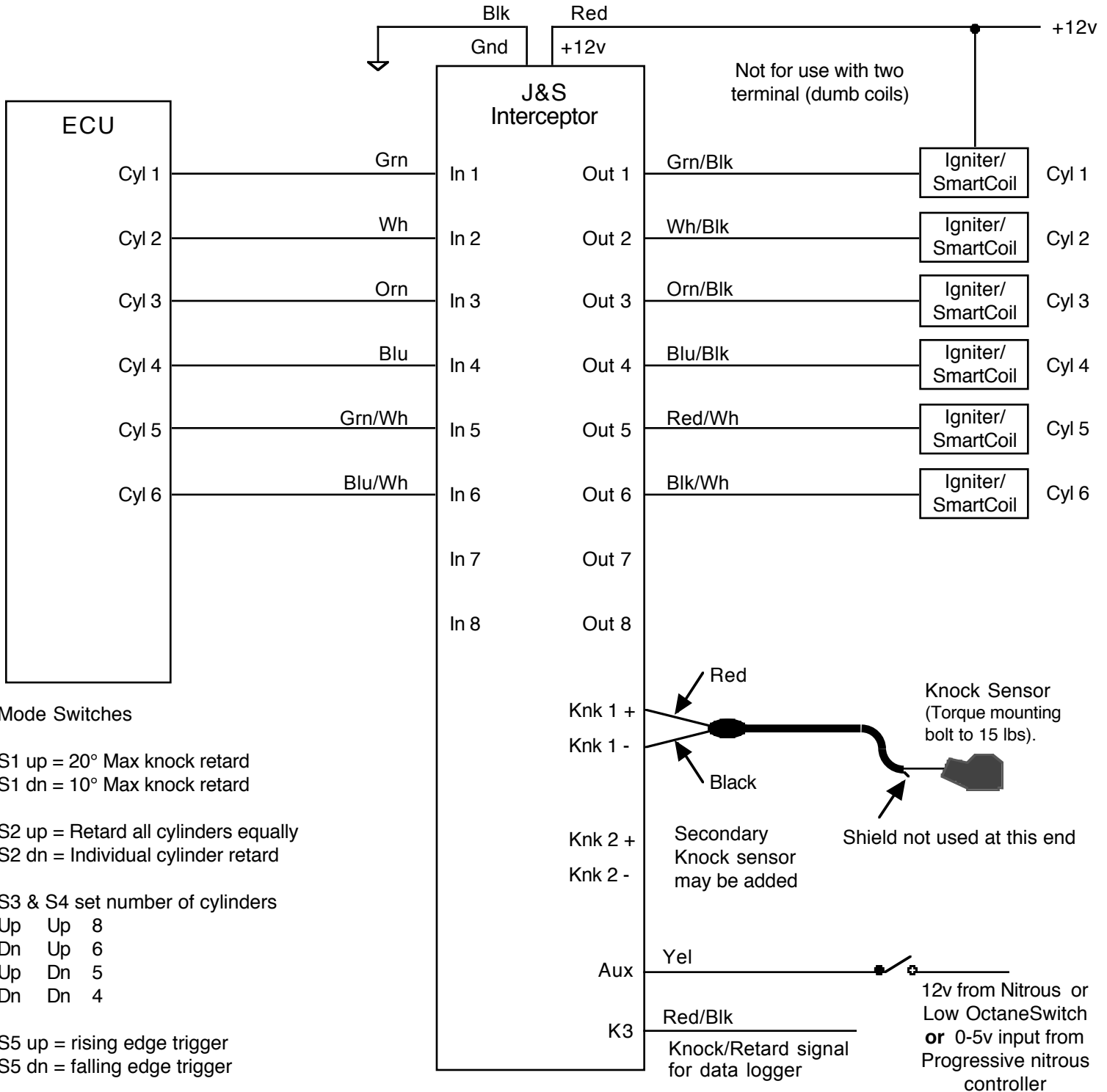

Note: Knock-Finder LED1 is related to channel 1, LED2 is related to channel 2, etc.

Knock.retard signal from the Monitor jack can be data logged if desired. Range is 0 to 1.3v. Signal is available at connector pin K3, Wh/Blk wire.

(Coils with internal igniter use falling edge)

S6 up = Closed loop knock controller
 S6 dn = Detector (no knock retard)

Detections visible on Status LED and optional bargraph gauge.