

J&S Electronics

for MR2 Spyder

13925 Parkway Dr. Garden Grove, CA 92843
 (714) 534-6975 www.jandssafeguard.com

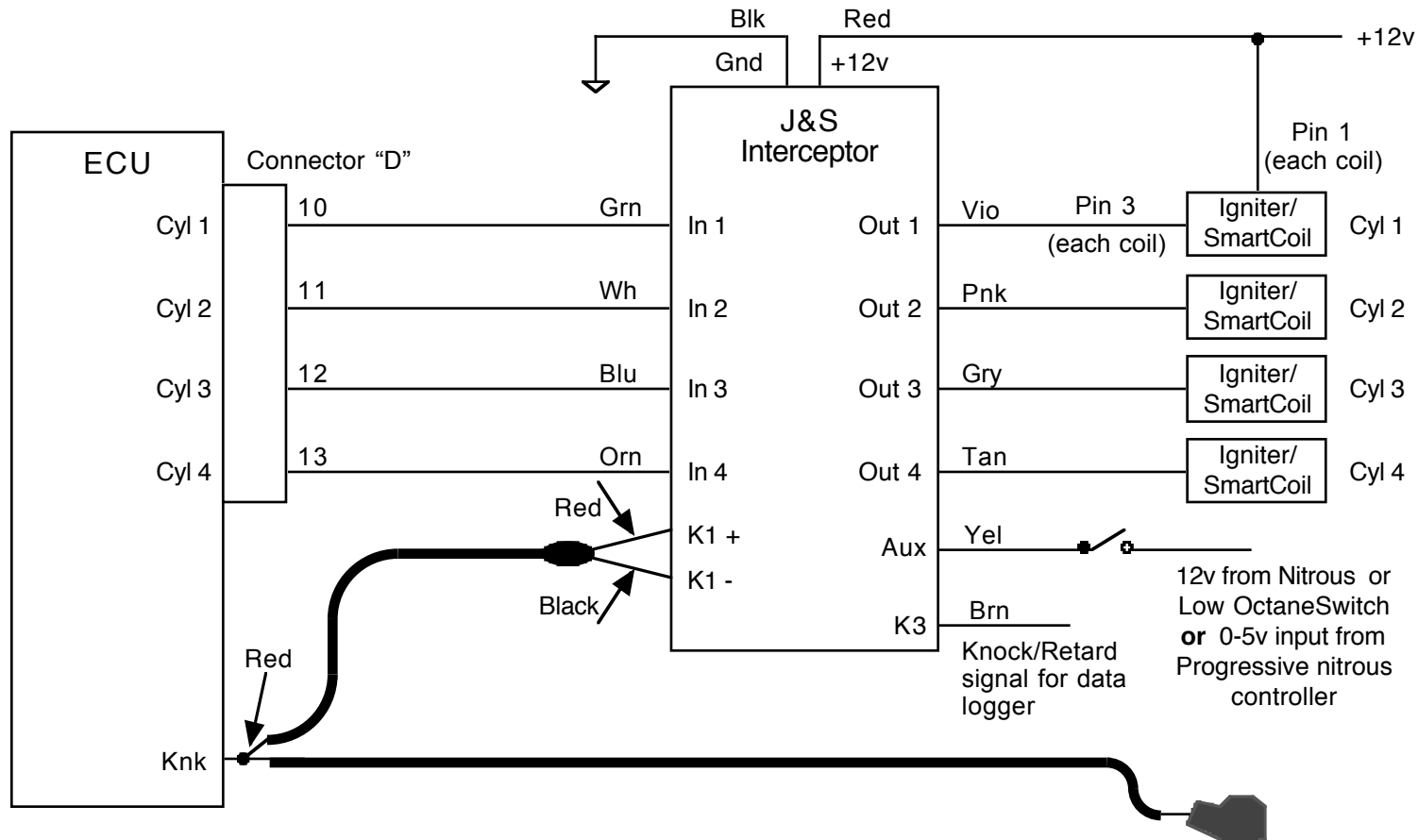

Mode Switches

S1 up = 20° Max knock retard
 S1 dn = 10° Max knock retard

S2 up = Retard all cylinders equally
 S2 dn = Individual cylinder retard

S3 & S4 set number of cylinders

Up	Up	8
Dn	Up	6
Up	Dn	5
Dn	Dn	4

S5 dn (falling edge trigger)

S6 up = Closed loop knock controller
 S6 dn = Detector (no knock retard)

In detector mode, detections are visible on Status LED and optional bargraph gauge, but knock-finder is disabled.

Factory Knock Sensor

Note: Knock-Finder LED1 is related to channel 1, LED2 is related to channel 2, etc.

Knock.retard signal from the Monitor jack can be data logged if desired. Range is 0 to 1.3v. Signal is available at connector pin K3, Brown wire.