

# J&S Electronics

13925 Parkway Dr. Garden Grove, CA 92843  
 (714) 534-6975 www.jandssafeguard.com

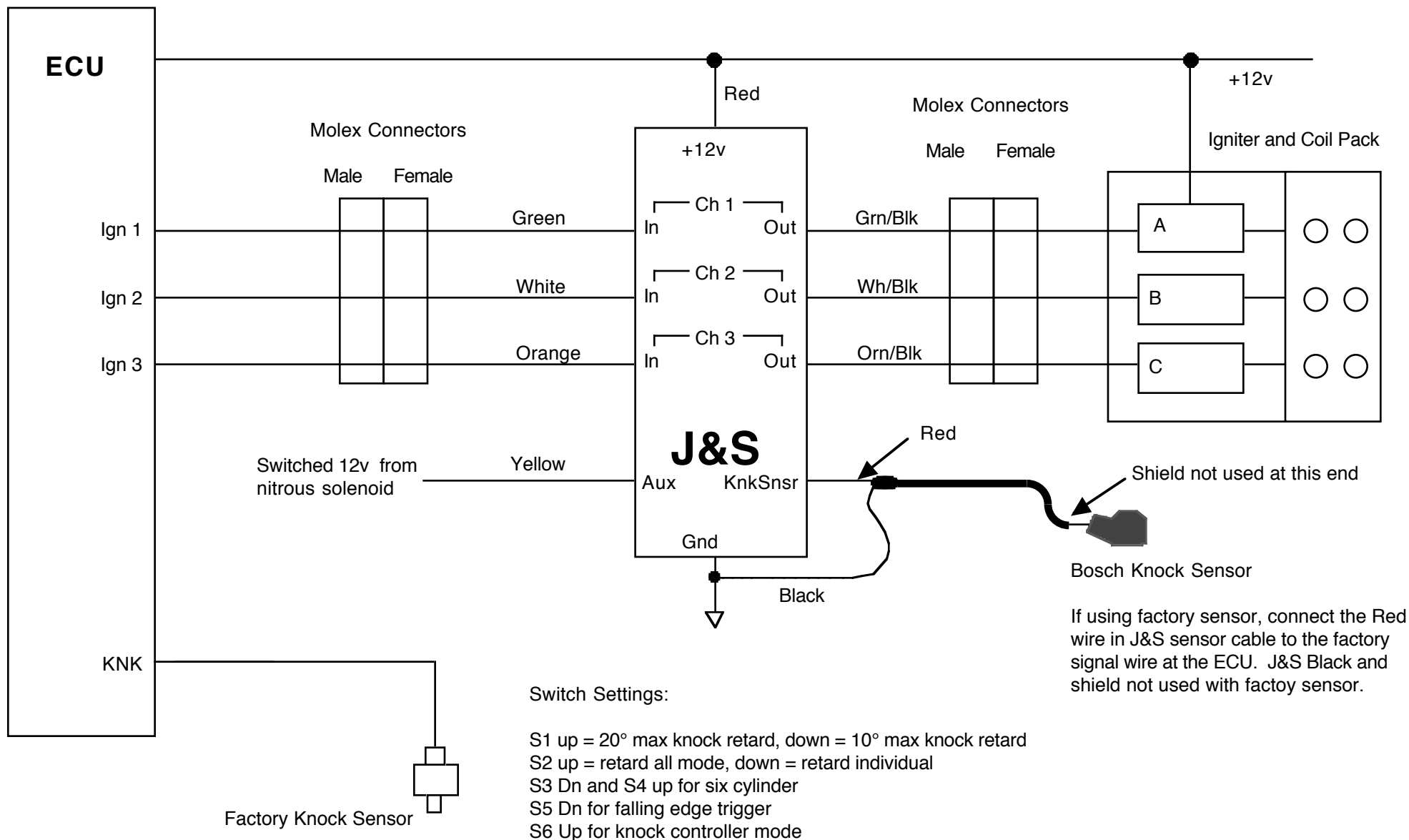

If using factory sensor, connect the Red wire in J&S sensor cable to the factory signal wire at the ECU. J&S Black and shield not used with factory sensor.